



General characteristics

Part numbers				
Geared motor		80362001	80362003	80362005
Geared motor + brake		80362101	80362103	80362105
Gearbox characteristics				
Gearbox type		RAD 20		
Max. radial force	N	1830	1830	1830
Max. axial force	N	366	366	366
RATIO		5	10	20
Max. allowed torque	Nm	20	20	20
Max. gear play	°	0,55	0,55	0,55

Geared motor characteristics at 32V (5)				
At no load				
Max. output speed	rpm	654	327	164
Standby current	mA	50	50	50
At nominal				
Speed	rpm	592	296	148
Torque (2)	Nm	4	7	13
Output power	W	242	222	201
Current	A	14,4	14,4	14,4
Efficiency	%	52	48	44
At max. output power				
Speed	rpm	432	240	140
Torque	Nm	12	20	20
Output power	W	543	503	292
Current	A	42	42	42
Efficiency	%	93	90	22
At peak torque				
Speed	rpm	432	240	140
Torque	Nm	12	20	20
Output power	W	543	503	292
Current	A	42	42	42
Others				
Weight without brake	kg	3,9	3,9	3,9
Weight with brake	kg	4,6	4,6	4,6

Connecting		
I/O M16 connector 18 pins	Pin N°	
Optional logic supply	1	
0 Volt	2	
Input 6 (analogic 1)	3	
Input 5 (analogic 2)	4	
Input 1 (digital)	5	
Input 2 (digital)	6	
Input 3 (digital)	7	
Input 4 (digital)	8	
0 Volt	9	
Output 1 (digital - PWM)	10	
Output 2 (digital - PWM)	11	
Output 3 (digital)	12	
Output 4 (digital)	13	
0 Volt	14	
STO 2 -	15	
STO 2 +	16	
STO 1 -	17	
STO 1 +	18	
Power supply M16 connector 3 pins	Pin N°	
Output ballast	1	
+VDC	2	
0 Volt	3	
CAN M12 Connector - 5 pins	Pin N°	
Not connected	1 / 2	
CAN_GND	3	
CAN_H	4	
CAN_L	5	
Brake connector	Pin N°	
0 Volt	1	
24 Vdc	3	
Not connected	4	

Motor Characteristics (1)		
Motor type		80 360 001 V1*
Direct current voltage supply		✓
Nominal voltage range	Vdc	9 --> 75
Max.current	A	75

Drive		
Type	SMI22 CAN	
Built-in drive		✓
Internal magnetic encoder		4096 pulses/rev
Setting software on PC		DCmind soft CAN Open
Control		
Position - speed - torque		✓
4 quadrants		✓
With regenerative energy absorber (3)		✓
Type" Field Oriented Control"		✓
Security		
Wrong polarity from power supply		✓
Output shortcut		✓
Input inverted		✓
Low voltage	Vdc	< 9
Overvoltage (4)	Vdc	> 75
Internal drive temperature protection	°C	250
Temperature drive allowing to restart	°C	90

Geared motor parameters			
Output shaft with ball bearings			✓
2 Safe Torque Off inputs	IEC61800-5-2/62061, ISO13849		✓
Temperature range	IEC60068-2-1/2	°C	-30 -> +70
Storage temperature		°C	-40 -> +80
Dielectric (1s/2mA)	IEC60335	Vdc	1 955
Motor insulation	IEC60085	class	E
Salt spray	ISO9227	severity	48h
EMC			
Electrostatic discharge	IEC61000-4-2	level	3
Radiated field	IEC61000-4-3	level	3
Electrical fast transient/burst test	IEC61000-4-4	level	3
Surge test	IEC61000-4-5	level	1
Conducted disturbances	IEC61000-4-6	level	3
Radiated emission	EN55022	class	B
Approvals			
ROHS	2011/65/CE		✓
EC			✓
UL			Pending
CAN Open	CIA 301 - DSP 402		✓
Communication			
USB (Setting, monitoring)			Micro-USB B
CAN open: address - node ID (factory settings)			0x20
CAN open: baud rate (factory settings)		kbaud	1 000

Brake characteristics		
Power OFF brake		YES
Voltage supply	Vdc	24 (+6% ; -10%)
Nominal holding torque	Nm	4,5
Input power	W	12

Notes	
Values without tolerances are average production values.	
(1) Cold motor, 20°C ambient temp., full speed, sinusoidal commutation	
(2) Nominal torque for continuous operation at 20 °C, decrease this value for higher ambient temperature	
(3) Ballast resistor to be added	
(4) Can be configured via DCmind soft+CANopen	
(5): Other values available, please refer to direct motor datasheet	
* V1: see label on product	

Additional information is available in the SQ75 product user manual and in the starter kit manual, available in www.crouzet.com

Drive electrical data

Running data

Parameters		Min.	Typical	Max.
Voltage power supply "Vdc"	Vdc	9	24	75
Current "Idc"	A	-	15	60
Standby power "Wo"	W	-	2	-
Voltage optional logic supply (see wiring diagram)	Vdc	9	-	75*

* UL: maximum voltage supply: 36 Vdc

CAN Bus characteristics

Parameters		Min.	Typical	Max.
CAN_L insulated	Vdc	0,5	1,5	2,25
CAN_H insulated	Vdc	2,75	3,5	4,5

Accessories

Starter kit

Part number **79 513 105**

Power/logic/CAN 3 m cables - Software - USB to Can Open adapter - CAN terminal resistor - CAN double connector

Power supply cable	79 298 664	3m length	AWG18
Input-Output cable	79 513 106	3m length	AWG24
CAN cable M12	27 358 015	1m length	AWG26

Wiring

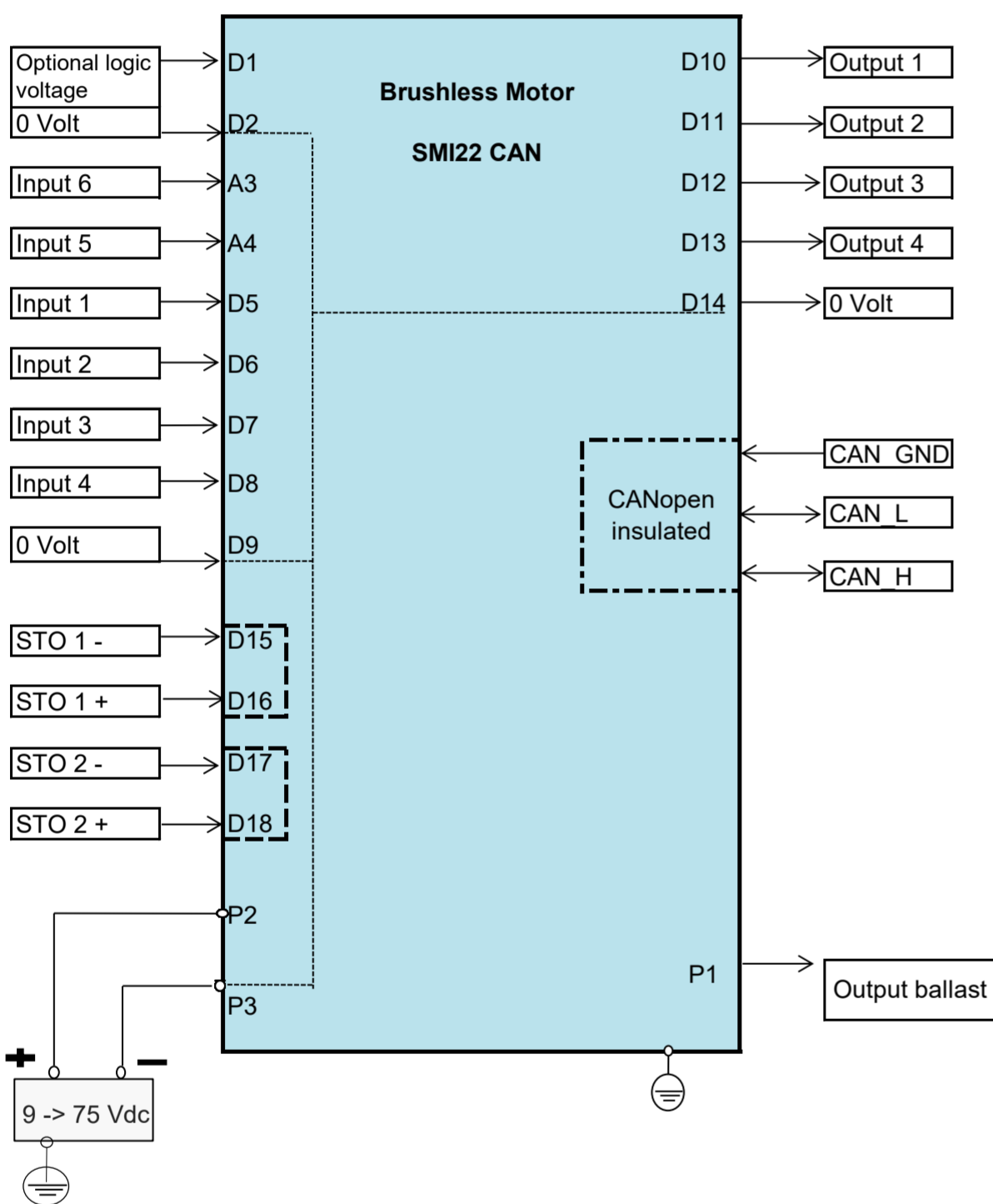

Input data

Parameters		Min.	Typical	Max.
Input 1, 2, 3, 4	Impedance	kΩ	-	247
	Low level	Vdc	-90	-
	High level	Vdc	4,5	-
Input 5, 6	Impedance	kΩ	-	159
	Low level	Vdc	-90	-
	High level	Vdc	7,1	-
Inputs STO	Low level	Vdc	-2	-
	High level	Vdc	4,6	-

Output data

Parameters		Min.	Typical	Max.
Low level Output 1, 2, 3, 4	mVdc	-	-	10
High level Output 1, 2, 3, 4	Vdc	-	4,75	-
Max output current "I outmax"	mA	-	-	50
I sink	mA	-	-	600

Input equivalent circuit

Inputs 1, 2, 3, 4

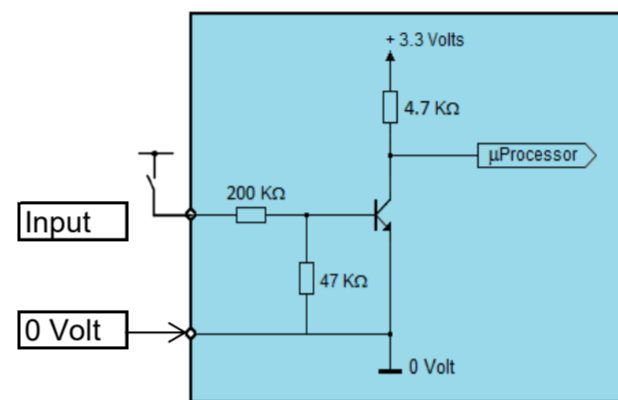

Inputs 5, 6

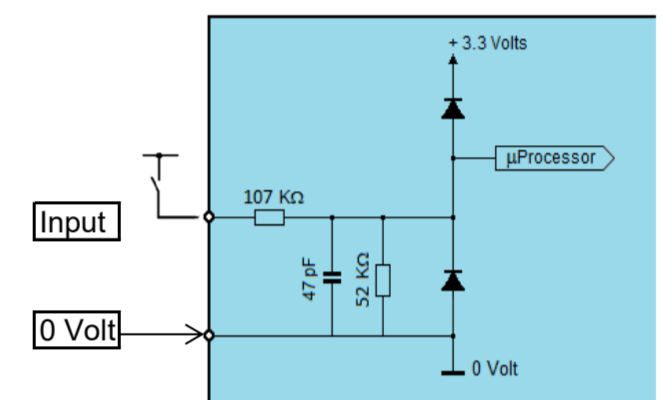

Output equivalent circuit

Output 1,2,3,4

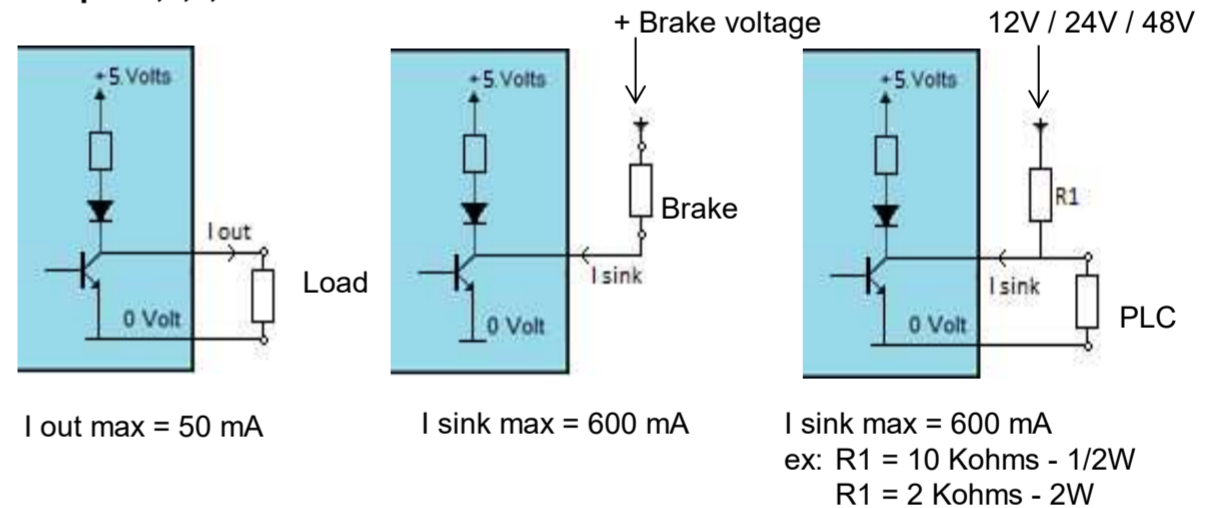

Output ballast

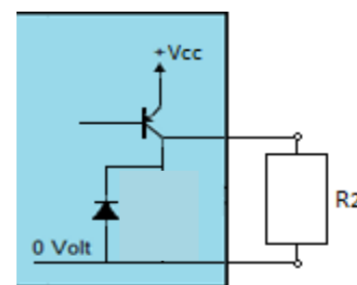

Regenerative energy created per inertia load creates over-voltage. In case of too high value, connect R2 resistor through ballast output and ground to absorb this energy. Typical R2 value is 2.2 Ω. Power value depends from machine inertia. Max. voltage can be set.

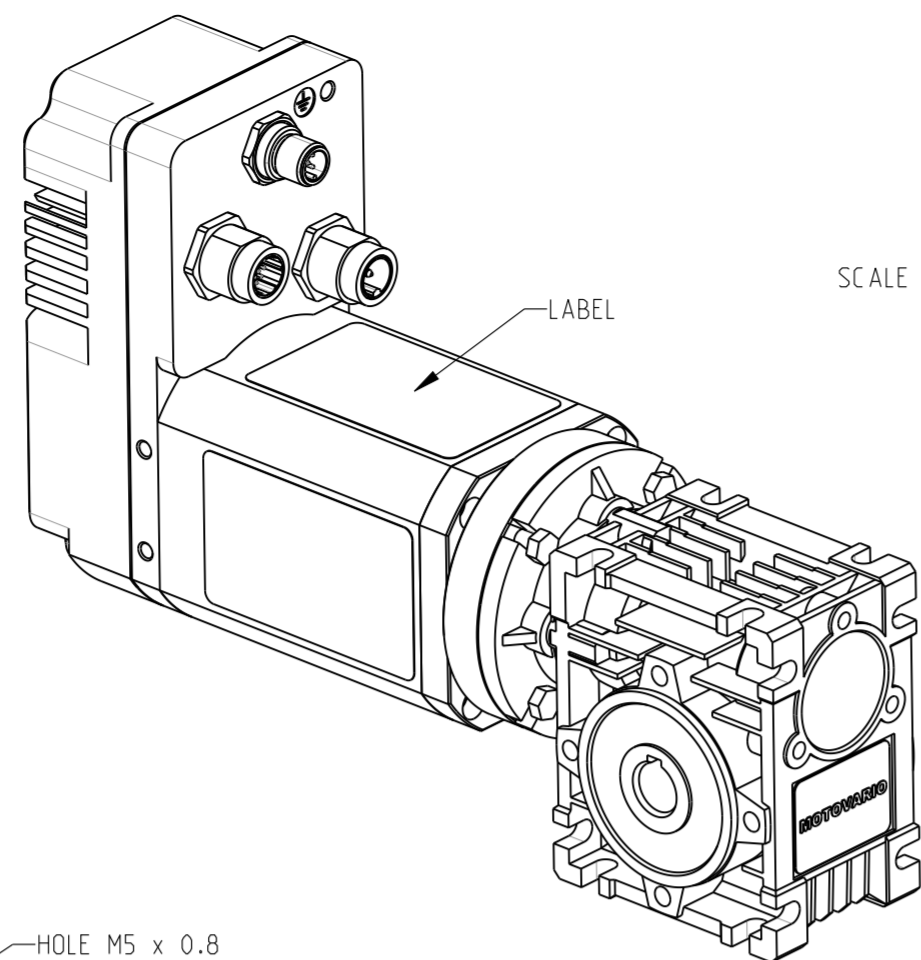

SCALE 1/2

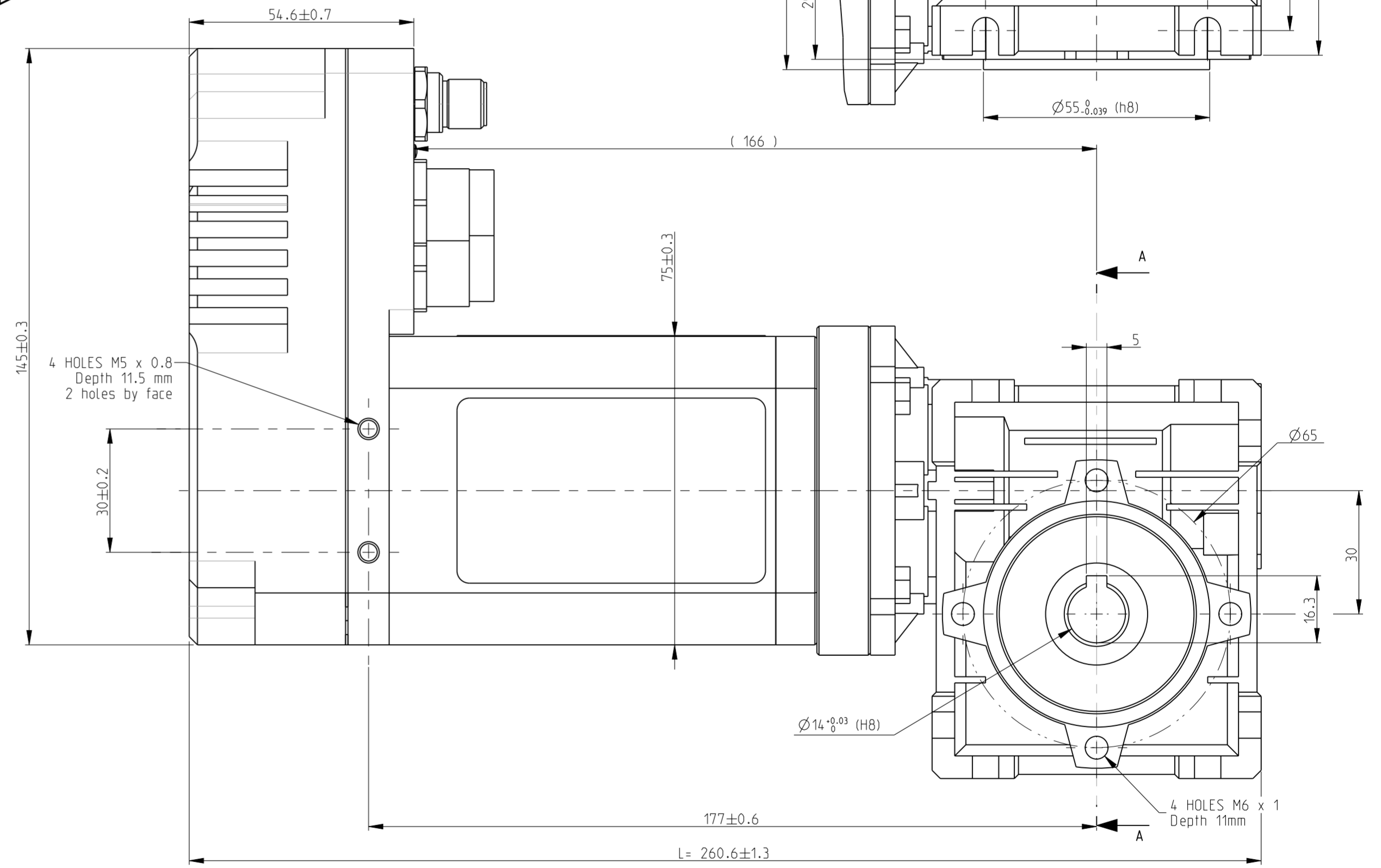
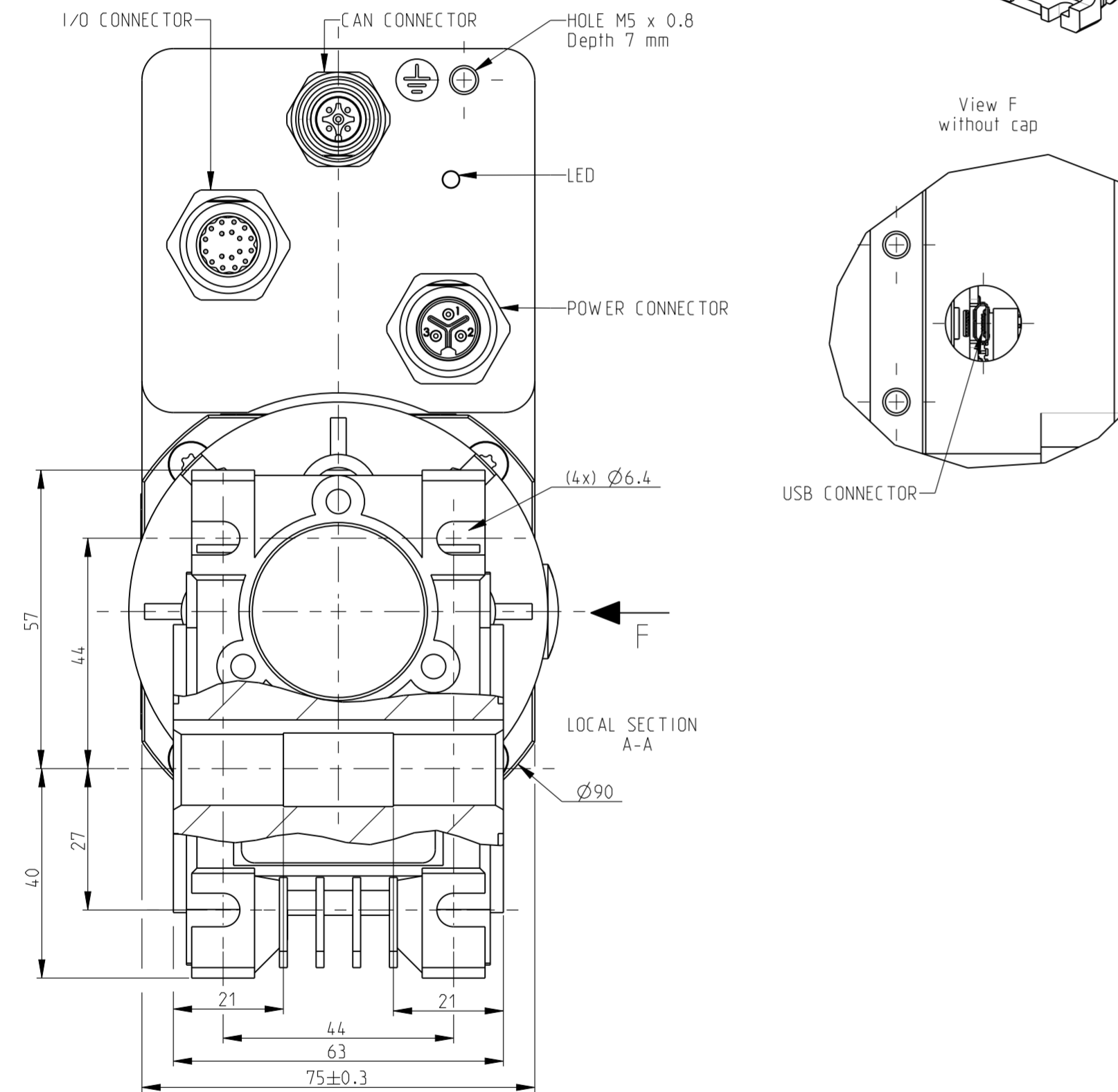
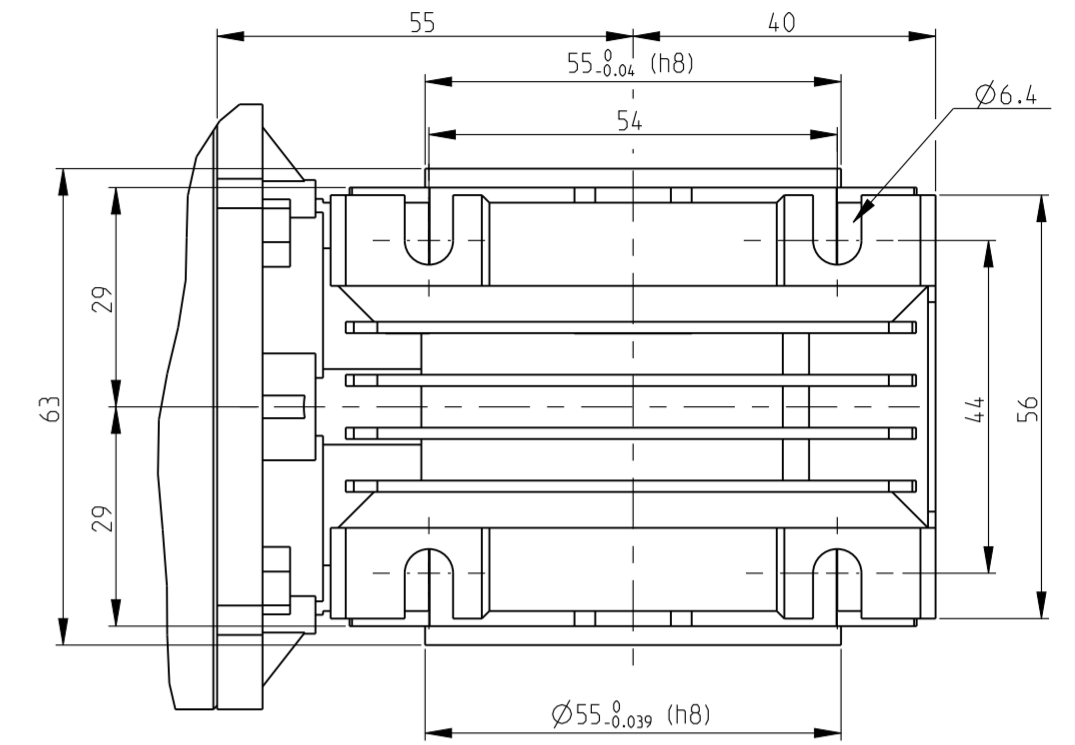
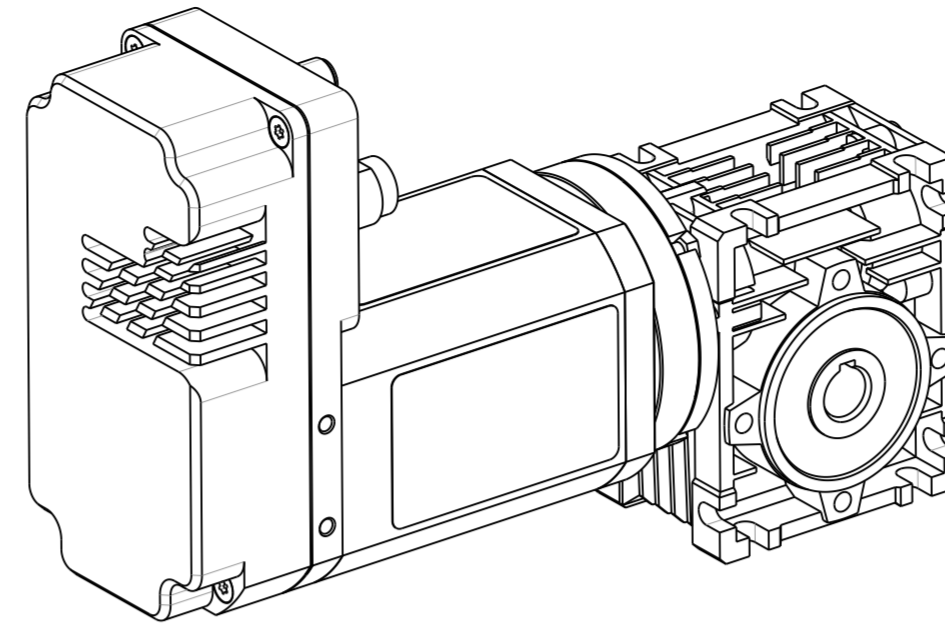

SQ75-2 80362 L: 2619 MAX

GEAR MOTOR AVAILABLE						
	80 362 001	80 362 002	80 362 003	80 362 004	80 362 005	80 362 006
RIGHT ANGLE GEARBOX CORRESPONDING						
RIGHT ANGLE GEARBOX AVAILABLE						
POIDS	1.2 Kg	1.2 Kg	1.2 Kg	1.2 Kg	1.2 Kg	1.2 Kg
JEU ANGULAIRE MAXI	0.5°	0.5°	0.5°	0.5°	0.5°	0.5°
DIAM_ARBRE_MOTEUR	11	11	11	11	11	11
PAM	56B14	56B14	56B14	56B14	56B14	56B14
REFERENCE FOURNISSEUR	NMRV03000511080	NMRV03000711080	NMRV03001011080	NMRV03001511080	NMRV03002011080	NMRV03003011080
RAPPORT	5	7.5	10	15	20	30
COULEUR	RAL 5010	RAL 5010	RAL 5010	RAL 5010	RAL 5010	RAL 5010
Reference	79298301	79298302	79298303	79298304	79298305	79298306

80360 V1 + RAD20



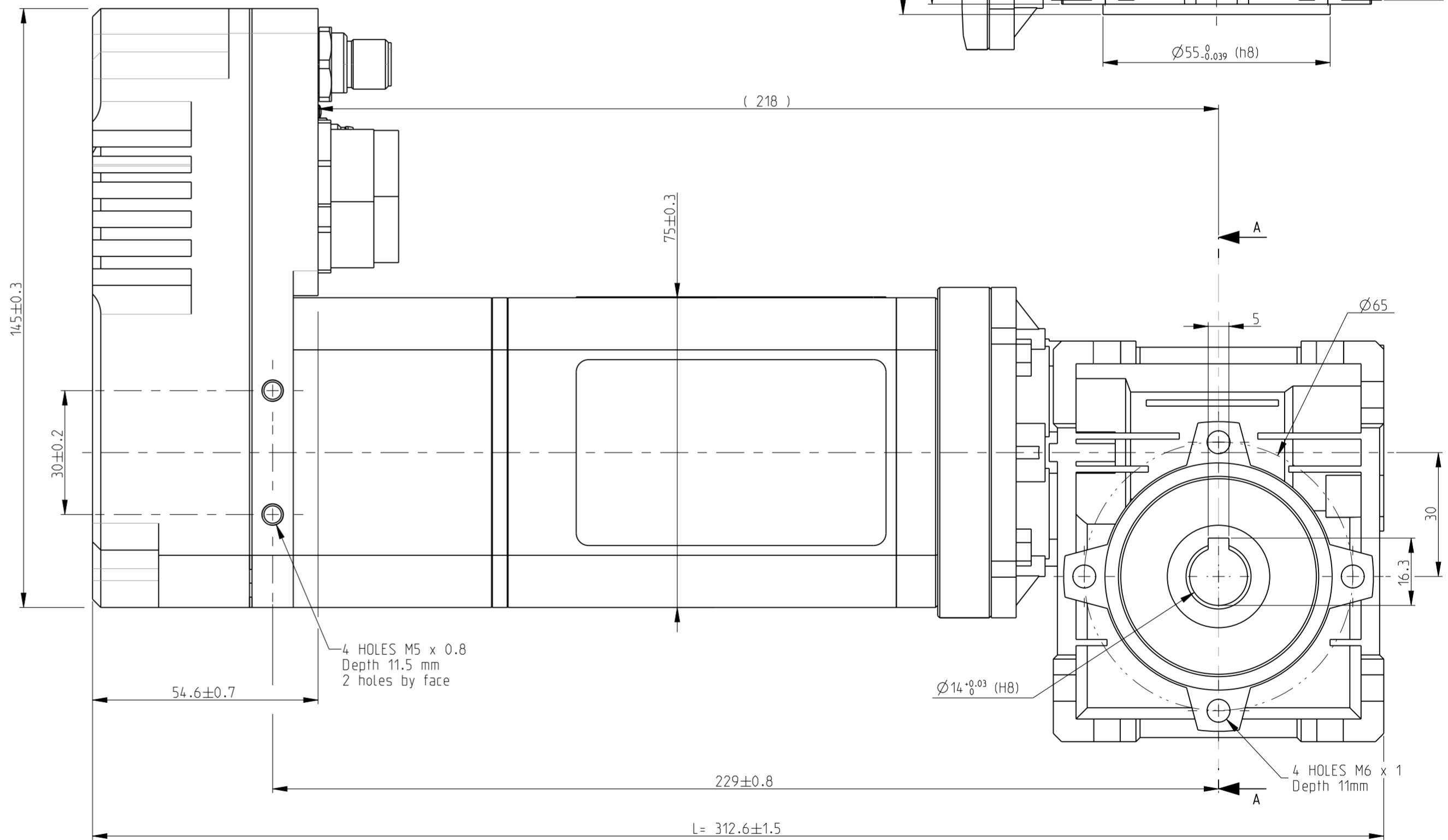
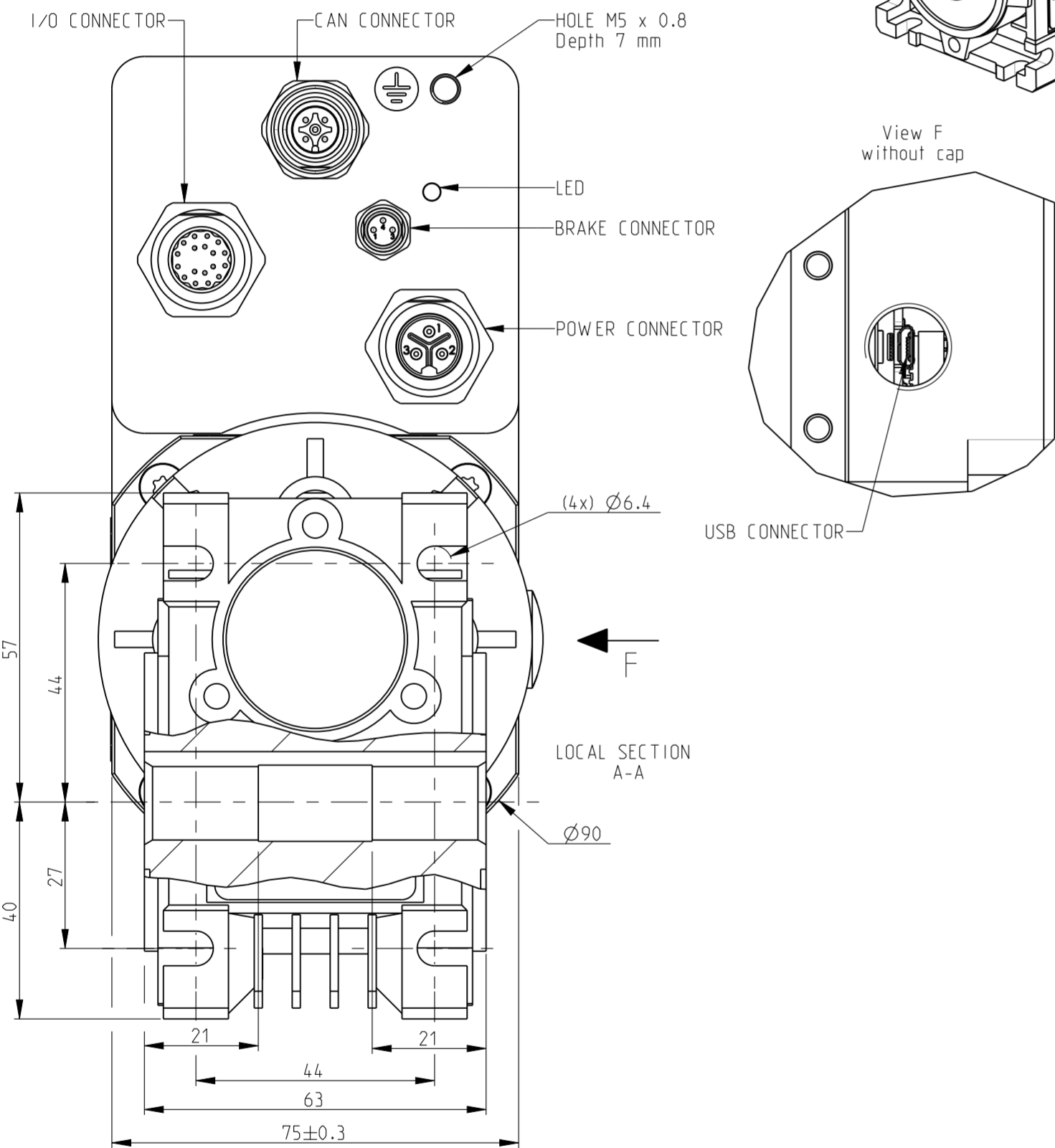
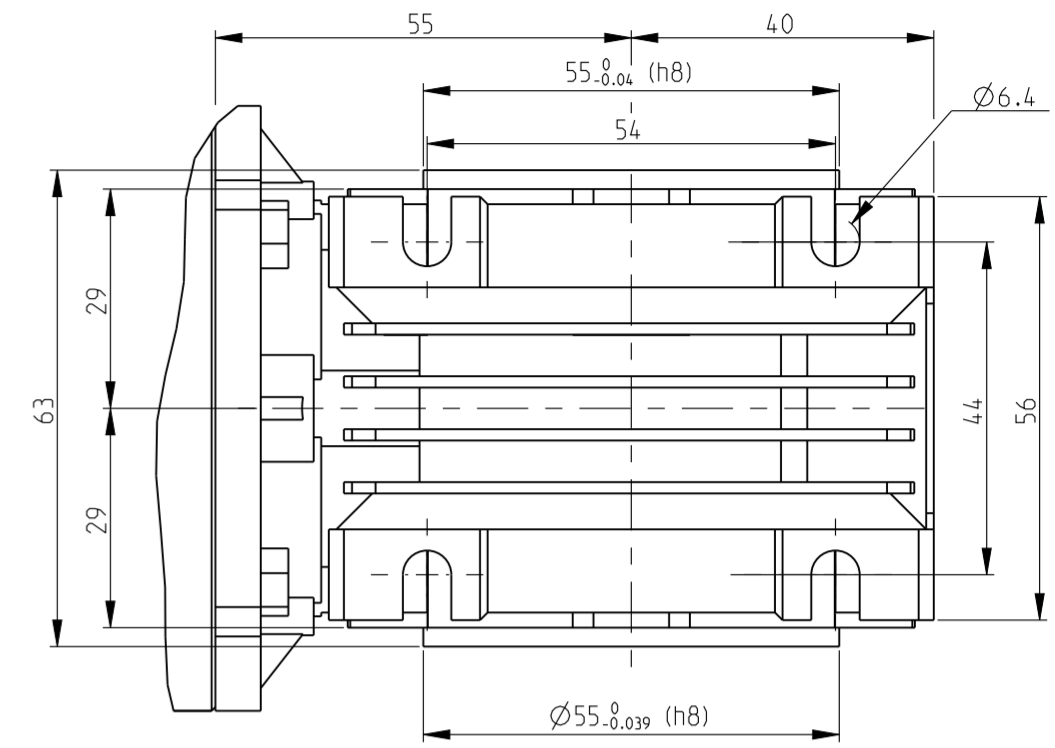
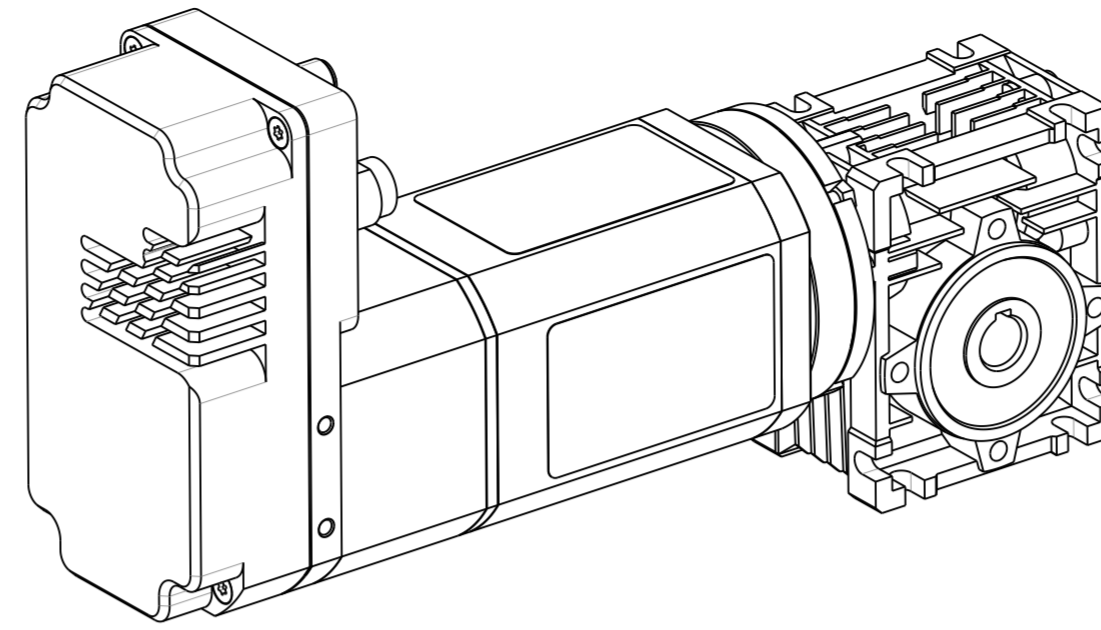
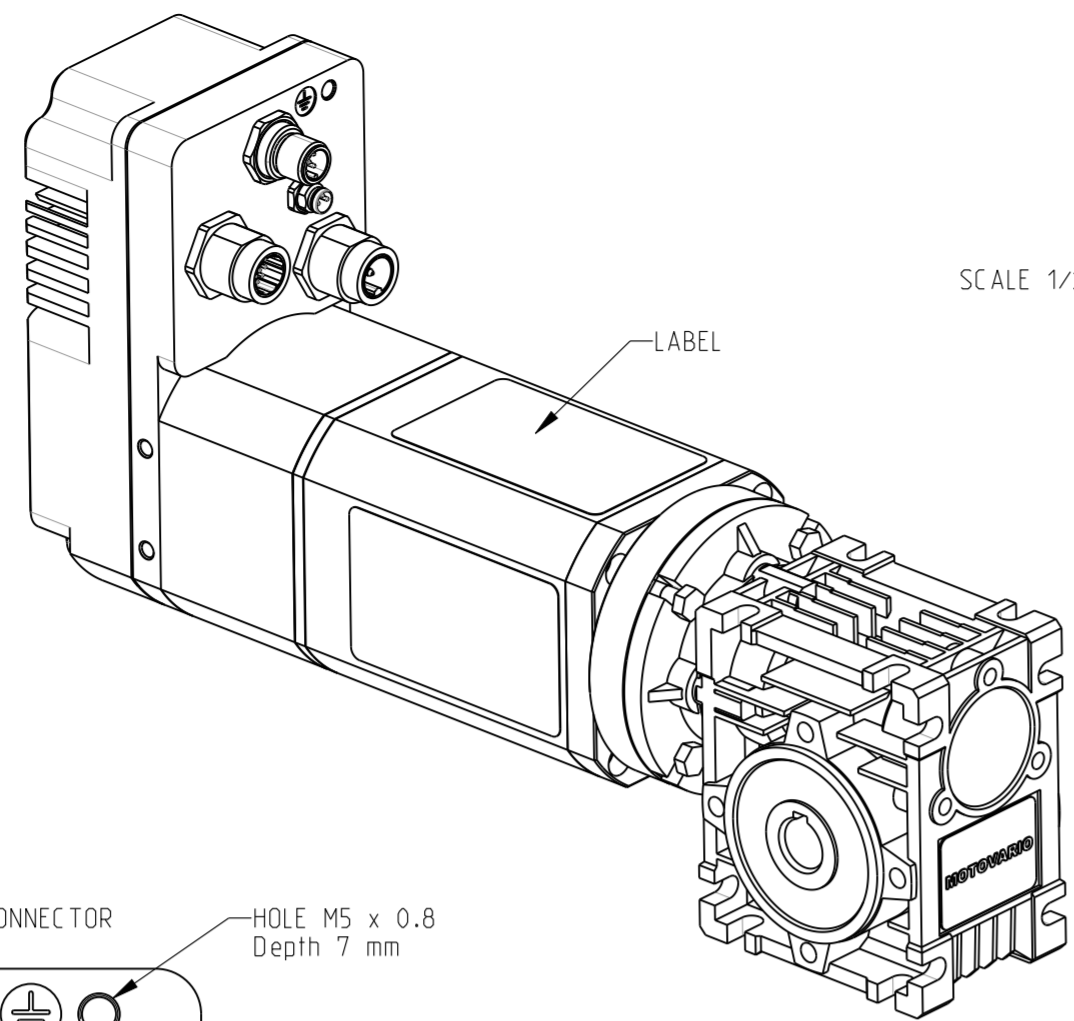

GEAR MOTOR AVAILABLE						
	80 362 101	80 362 102	80 362 103	80 362 104	80 362 105	80 362 106
RIGHT ANGLE GEARBOX CORRESPONDING						
RIGHT ANGLE GEARBOX AVAILABLE						
POIDS	1.2 Kg	1.2 Kg	1.2 Kg	1.2 Kg	1.2 Kg	1.2 Kg
JEU ANGULAIRE MAXI	0.5°	0.5°	0.5°	0.5°	0.5°	0.5°
DIAM_ARBRE_MOTEUR	11	11	11	11	11	11
PAM	56B14	56B14	56B14	56B14	56B14	56B14
REFERENCE FOURNISSEUR	NMRV03000511080	NMRV03000711080	NMRV03001011080	NMRV03001511080	NMRV03002011080	NMRV03003011080
RAPPORT	5	7.5	10	15	20	30
COULEUR	RAL 5010	RAL 5010	RAL 5010	RAL 5010	RAL 5010	RAL 5010
Reference	79298301	79298302	79298303	79298304	79298305	79298306

80360 V1 + RAD20 + BRAKE

