

### Starting/running torque from 30 and 37.5 mN.m 3.5 Watts Part number 825204



- Constant speed, dependent on supply frequency
- Direction of rotation controlled by dephasing capacitor
- Sintered bearing lubricated for life
- Silent operation
- UL, CSA (classe B)

#### Part numbers

	Type	Type	Voltages/Frequencies
825204	3.5 Watts	82 520 4	230-240 V 50 Hz

#### Specifications

Base speed of motor (rpm)	375
Absorbed power (W)	3,5
Usable Power (W)	1,12
Starting/running torque (mNm)	30
Stall torque (mNm)	31
Temperature rise (°C)	55
Ambient temperature (°C)	-10+75
Maximum inertial load that can be moved (g.cm <sup>2</sup> )	33
Number of offload starts	
Insulation resistance (MΩ)	75x10 <sup>3</sup>
Breakdown voltage (V-50 Hz)	1800 -1 sec.
Weight (g)	210
Wires length mm (approximately)	250
Protection rating	IP40

#### Accessories

Voltages/Frequencies	µF	V AC	Code
Capacitors motor 82 520 4	Condensateur		
230/240 V - 50 Hz	0,12 ± 10 %	480	26 231 903
115 V - 60 Hz	0,39 ± 5 %	480	26 231 924
24 V - 50 Hz	15 ± 5 %	63	26 231 728
24 V - 60 Hz	12 ± 5 %	63	26 231 145

#### Dimensions (mm)

82 520 4

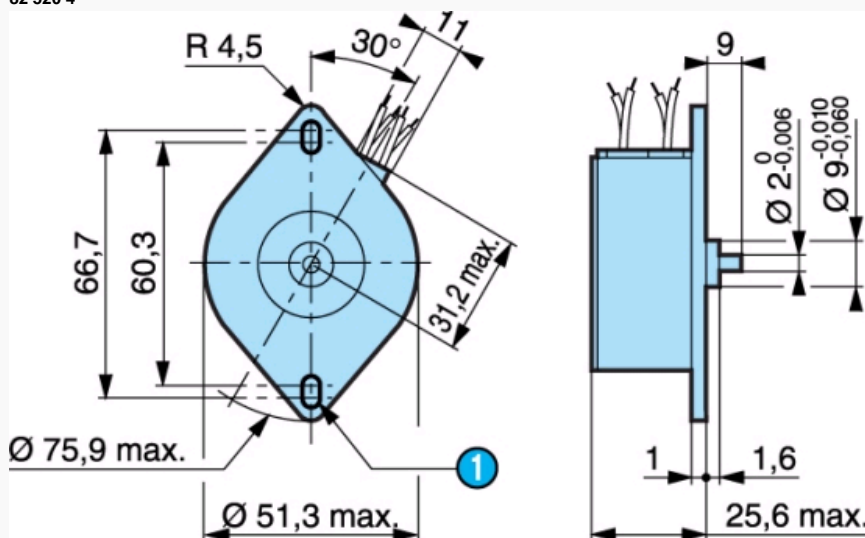

N°	Legend
①	2 oblong fixing holes 3.5 wide

### Connections

In parallel

Motors 82 520 0 - 82 520 4

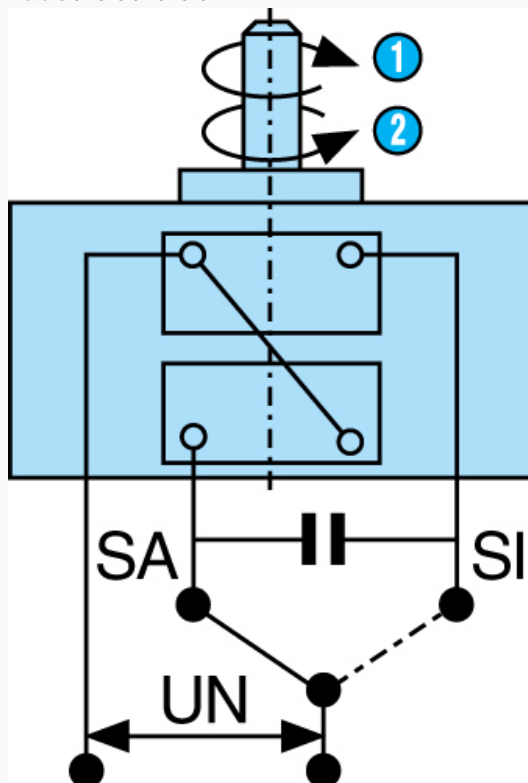

N°	Legend
①	SA : clockwise
②	SI : anti-clockwise

### Product adaptations



- Different voltages available
- Pinion on output shaft
- Special output shafts
- Special supply voltages
- Special cable lengths
- Special output bearings
- Special mounting plate
- Special connectors